

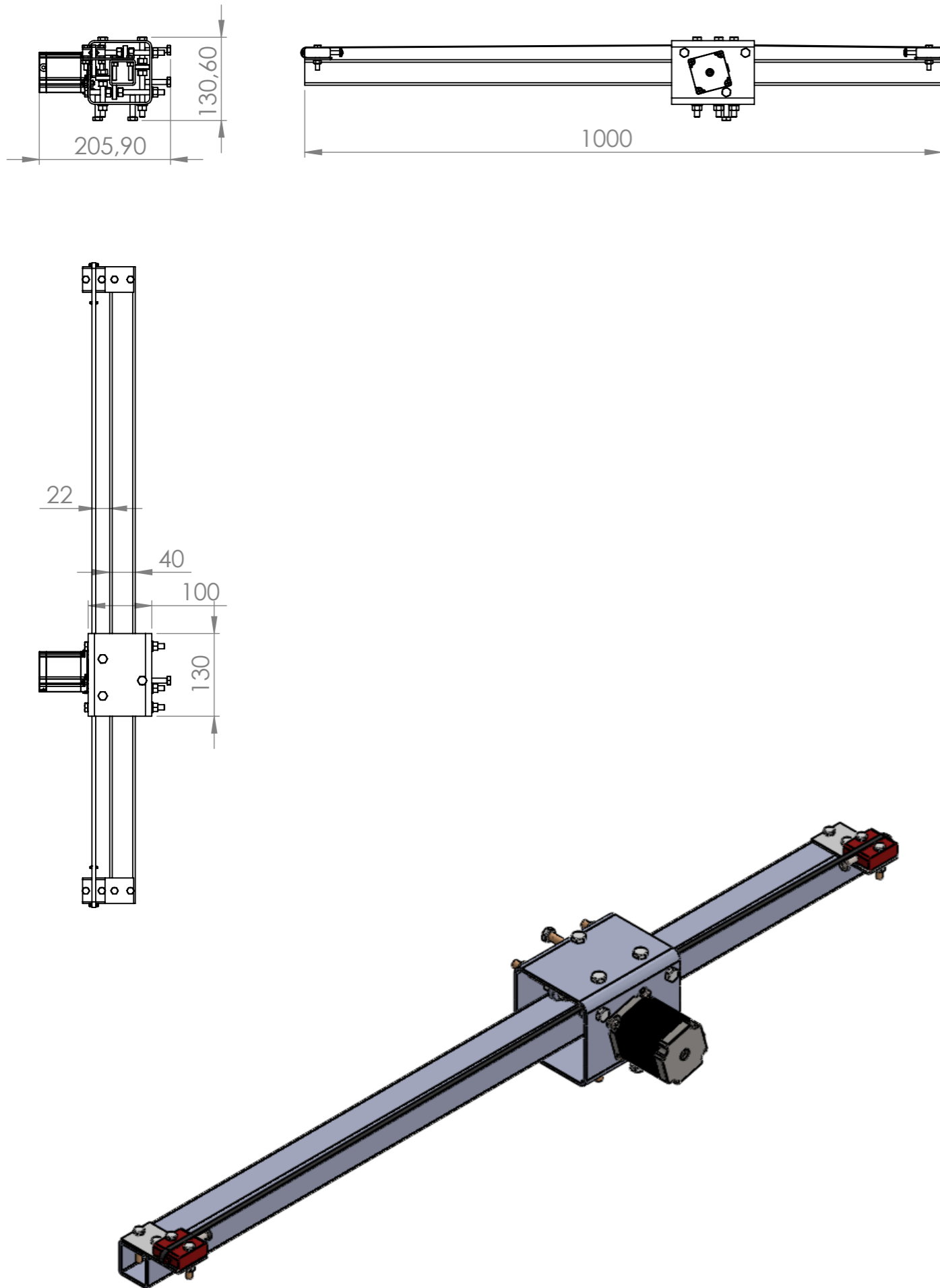



UNLESS OTHERWISE SPECIFIED: DIMENSIONS ARE IN MILLIMETERS SURFACE FINISH: TOLERANCES: LINEAR: ANGULAR:				 www.irnas.eu		DEBUR AND BREAK SHARP EDGES	DO NOT SCALE DRAWING	REVISION
DRAWN	NAME	SIGNATURE	DATE				TITLE:	
CHK'D								
APPV'D								
MFG								
Q.A					MATERIAL:		DWG NO.	Plasma-XY-V0.3
							SCALE:1:5	A3
					WEIGHT:		SHEET 1 OF 1	

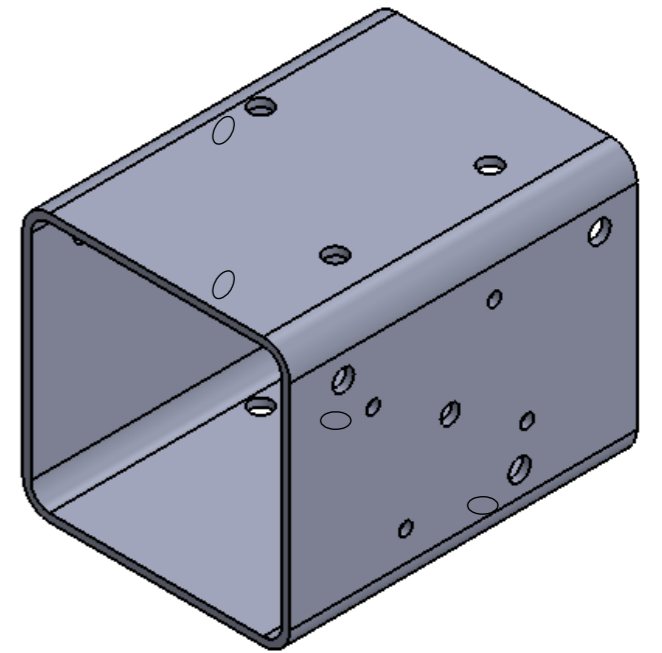
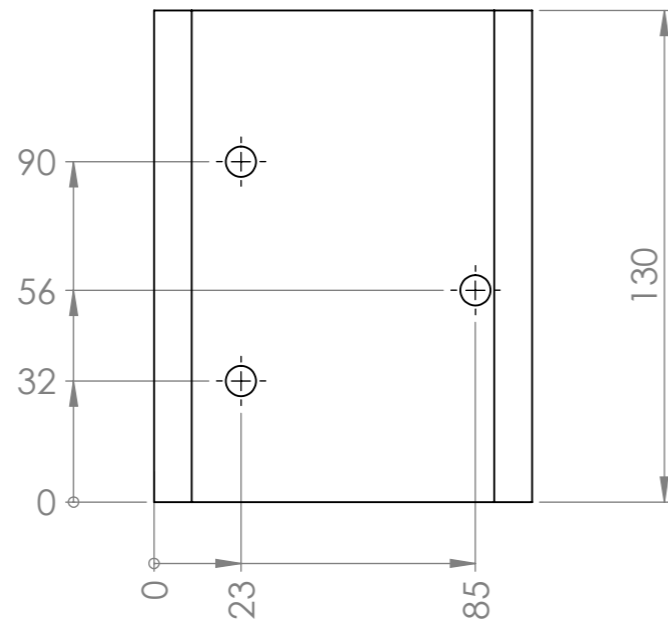
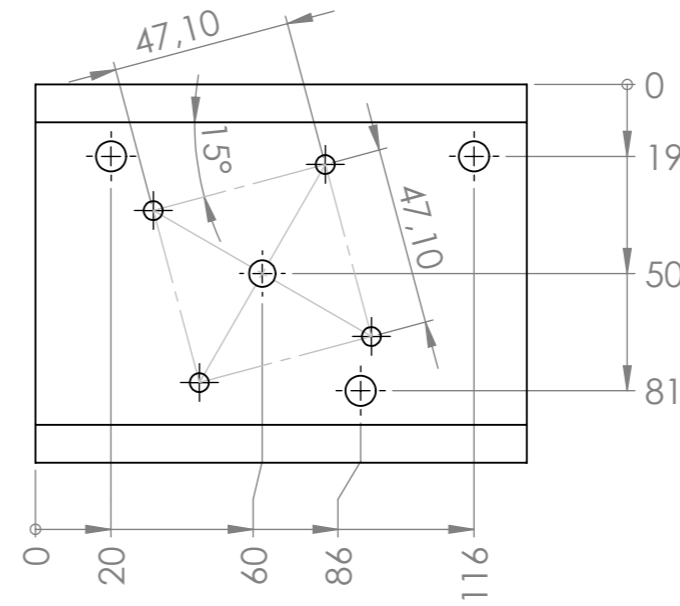
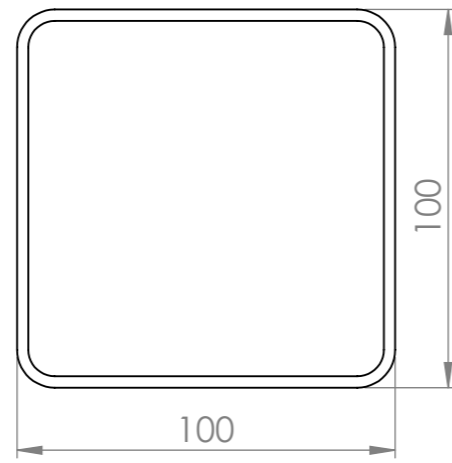
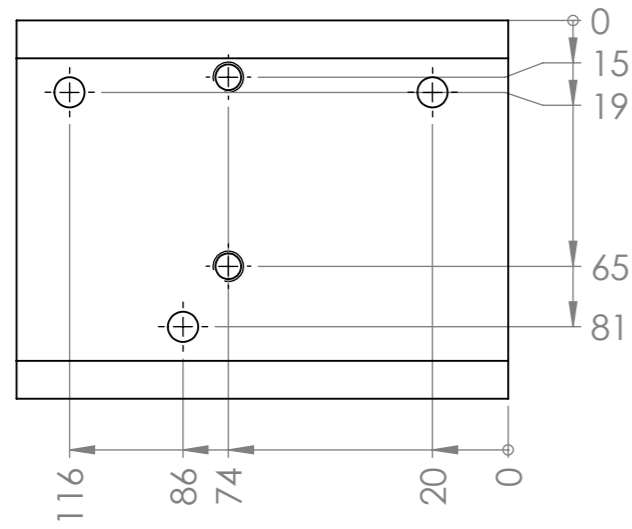
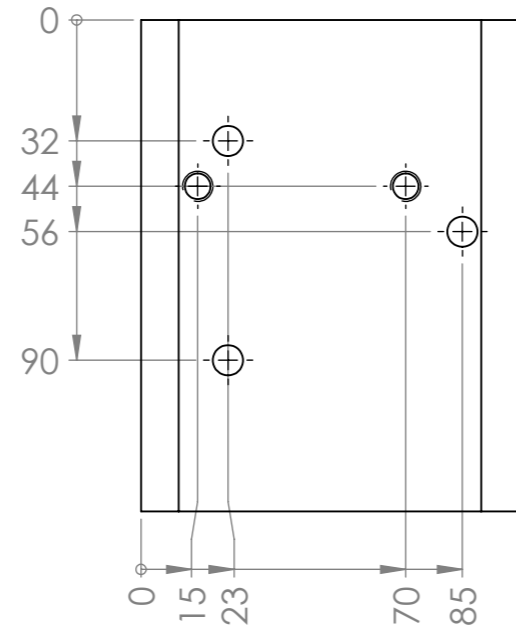

ITEM NO.	QTY.	PART NUMBER	DESCRIPTION
1	1	Profile-40x40x3-1000mm - X	
2	1	MountV0.3	
2.1	1	Profile-100x100x2-130mm-V0.3	
2.2	6	DIN_933_M8x120	DIN 933 M8x75 POCINKANO
2.3	6	Bearing 608ZZ	Bearing 608ZZ
2.4	4	Belt bearing F608Z	
2.5	1	Stepper motor NEMA 23HS7430	
2.6	1	Timing pulley T2 6mm 20 teeth	
2.7	4	M5	Kunststoffscheibe aus Polyamid in den größen M2 - M20.
2.8	4	ISO 7045 - M5 x 16 - Z --- 16N	
2.9	4	Mutter DIN-934 M5-A2	Mutter DIN-934 Dimensionen: M2,5 - M16
2.10	10	M8	Kunststoffscheibe aus Polyamid in den größen M2 - M20.
2.11	4	Default	DIN 933 M8x35 POCINKAN
2.12	12	Spring Washer M8 2146-025	M8 SPRING WASHER
2.13	18	Default	DIN 934 M8 POCINKAN
3	2	Tightener	
3.1	1	Tightener - plate	
3.2	1	Tightener - housing	
3.3	1	Tightener - stick	
3.4	2	DIN_933_M6x35	DIN 933 M6x35 POCINKAN
3.5	2	DIN 6902-C4.55	
3.6	2	DIN_934_M6	DIN 934 M6 POCINKANO
3.7	1	ISO 7045 - M6 x 30 - Z --- 30N	
4	4	DIN_933_M6x35	DIN 933 M6x35 POCINKAN
5	4	DIN 6902-C5.5	
6	4	DIN_934_M6	DIN 934 M6 POCINKANO
7	1	Timing belt T2 6mm	

UNLESS OTHERWISE SPECIFIED: DIMENSIONS ARE IN MILLIMETERS SURFACE FINISH: TOLERANCES: LINEAR: ANGULAR:				 www.irnas.eu		DEBUR AND BREAK SHARP EDGES		DO NOT SCALE DRAWING		REVISION	
NAME	SIGNATURE	DATE						TITLE:			
DRAWN											
CHK'D											
APPV'D											
MFG											
Q.A						MATERIAL:		DWG NO.	Gantry X	A3	
						WEIGHT:		SCALE:1:8	SHEET 1 OF 1		



UNLESS OTHERWISE SPECIFIED: DIMENSIONS ARE IN MILLIMETERS SURFACE FINISH: TOLERANCES: LINEAR: ANGULAR:				 www.irnas.eu		DEBUR AND BREAK SHARP EDGES		DO NOT SCALE DRAWING		REVISION	
DRAWN		SIGNATURE				DATE		TITLE:			
CHK'D											
APPV'D											
MFG											
Q.A						MATERIAL:		DWG NO.		Trolley	
						WEIGHT:		SCALE:1:2		SHEET 1 OF 1	
										A3	